

**Six-Monthly Environmental Compliance Report of  
Stipulated Conditions of Environmental Clearance  
(JUNE, 2023)**

**Of**

**CONSTRUCTION OF GROUP HOUSING PROJECT**

**At**

**SURVEY NO. 15/1, 33/1, WARD NO. 21, KODENCHERY  
PANCHAYATH, DISTRICT CALICUT, KERALA**



**Submitted by**

**M/s. Calicut Landmark Builders & Developers (India) Pvt. Ltd.**  
**3rd Floor, CD Tower,**  
**Mini Bypass Road,**  
**Kozhikode-4, Kerala, India.**

**LIST OF ANNEXURES**

<b>SI. NO.</b>	<b>ANNEXURES</b>	<b>Page No</b>
<b>I.</b>	Copy of Consent for Establishment from Kerala State Pollution Control Board under Air and Water Act	38
<b>II.</b>	Photographs showing conducting various health related camps for workers	39-42
<b>III</b>	Photo showing the topsoil excavated used for landscape development	43
<b>IV</b>	Soil investigation report	44-52
<b>V</b>	Water testing report	53-55
<b>VI</b>	Photograph showing ready mixed concrete plant	56
<b>VII</b>	Photograph showing diesel generators	57-59
<b>VIII</b>	Copy of Pollution Under Check certificate for the vehicles	60
<b>IX</b>	Noise levels & air monitoring reports	61-63
<b>X</b>	Dual plumbing plan	64-65
<b>XI</b>	Copy of the structural certificate	66
<b>XII</b>	Copy of Fire NOC	67

<b>XIII</b>	Photographs showing proper barricading to avoid disturbance to the surroundings	68
<b>XIV</b>	Copy of newspaper advertisement	69

## **CHAPTER- 1** **INTRODUCTION**

**1. Project Type:** Building and Construction project

**2. Project Category:** Project comes under Category 8 (a) of EIA Notification 2006 and its amendments.

**3. Name of Project:**Construction of Group Housing Projectby M/s. Calicut Landmark Builders & Developers (India) Pvt. Ltd

**4. Location of Project:** survey no. 15/1, 33/1, Ward no. 21, Kodenchery Panchayath, District Calicut, Kerala

**5. Environmental Clearance letter/OM No. & Date:** Environmental Clearance from SEIAA Kerala 73/2019 DATED 28<sup>th</sup> DECEMBER, 2019)

**6. Address of Correspondence:**

M/s. Calicut Landmark Builders & Developers (India) Pvt. Ltd.  
3rd Floor, CD Tower,  
Mini Bye Pass Road,  
Kozhikode-4, Kerala, India

**7. Compliance Period:** January 2023

## **CHAPTER -2** **STATUS OF THE PROJECT**

MoEF has accorded EC for construction of Group Housing Project at Survey no. 15/1, 33/1, ward no. 21, Kodenchery Panchayath, District Calicut, Kerala on a plot area of 7.82 ha and total built up area of 1,45,000m<sup>2</sup> by M/s. Calicut Landmark Builders & Developers (India) Pvt. Ltd

Construction of the Group Housing project status given below,

**CONSTRUCTION STATUS**

<b>CONSTRUCTION STATUS OF GROUP HOUSING PROJECT</b> At Re-survey No. 15/1,33/1, Ward No. 21, at KodencheryPanchayat, District Calicut, Kerala	
<b>TOWER NAME</b>	<b>STATUS</b>
Tower 1	Tentatively Handed over.
Tower 2	Finishing Work in progress.
Tower 3	Structure Work in progress. –Terrace Floor Slab
Tower 4	Not Started.
Tower 5	Not Started.
Tower 6	Structure Work in progress. – Terrace Floor Slab
Infrastructure Works	In Progress.

## **CHAPTER -3**

### **PURPOSE OF THE REPORT**

This six-monthly report will be submitted as per the conditions stipulated in the Environmental Clearance letter.

Further, the study will envisage the environmental impacts that have generated in the local environment due to the project.

The environmental assessment is being carried out to verify:

- That the project does not have any adverse environmental impacts in the project area and its surrounding
- Compliance with the conditions stipulated in the Environmental Clearance Letter.
- That the Project Management is implementing the environmental mitigation measures as suggested in the approved Form-I, Form-IA and Environmental Management Plan (EMP).

---

**CHAPTER-4**  
**ENVIRONMENTAL CLEARANCE LETTER COPY**





Validity expires on 27.12.2026

**PROCEEDINGS OF THE ADMINISTRATOR, STATE ENVIRONMENT IMPACT ASSESSMENT AUTHORITY, THIRUVANANTHAPURAM (Present. Sabitha.S)**

Sub: SEIAA- Environmental clearance for the proposed "Township" Project at Sy Nos. 15/1 & 33/1 at Kodenchery Village, Kozhikode Taluk & Kozhikode District, Kerala by Sri Anwar Sadath, Director, M/s Calicut Landmark Builders & Developers (India) Pvt. Ltd. Landmark World, N.H.17 Bypass, Kozhikode, Kerala-673014 - Environmental Clearance granted - Orders issued

**STATE ENVIRONMENTAL IMPACT ASSESSMENT AUTHORITY**

**No. 909/SEIAA/EC4/3588/2015**

**Dated, Thiruvananthapuram 28.12.2019**

- Ref:
1. Application dated 4-9-2015, from Sri.Anwar Sadath, Director, M/s Calicut Landmark Builders & Developers (India) Pvt. Ltd. Landmark World, N.H.17 Bypass, Kozhikode, Kerala-673014.
  2. Minutes of 36<sup>th</sup> meeting of SEAC held on 6<sup>th</sup> & 7<sup>th</sup> June 2016.
  3. Minutes of the 59<sup>th</sup> meeting of SEAC held on 11-12 July 2016.
  4. Minutes of 58<sup>th</sup> meeting of SEIAA held on 08.9-2016.
  5. Minutes of the 63<sup>rd</sup> meeting of SEAC held on 4<sup>th</sup> October, 2016
  6. Minutes of the 61<sup>st</sup> meeting of SEIAA held on 30-11-2016
  7. Minutes of the 73<sup>rd</sup> meeting of SEIAA held on 15-9-2017
  8. Minutes of the 98<sup>th</sup> meeting of SEIAA held on 18<sup>th</sup> & 19<sup>th</sup> September 2019
  9. Minutes of the 99<sup>th</sup> Meeting of SEIAA held on 21<sup>st</sup> & 22<sup>nd</sup> November 2019
  10. Minutes of the 100<sup>th</sup> Meeting of SEIAA held on 23<sup>rd</sup> & 24<sup>th</sup> December 2019

**ENVIRONMENTAL CLEARANCE NO.73 /2019**

Sri.Anwar Sadath, Director, M/s Calicut Landmark Builders & Developers (India) Pvt. Ltd. Landmark World, N.H.17 Bypass, Kozhikode, Kerala-673014), vide his application received on 7-9-2015 has sought environmental clearance under the EIA Notification, 2006 for the proposed "Township" Project of total plot area of 7.8269 ha at Sy Nos. 15/1 & 33/1 at Kodenchery Village, Kozhikode Taluk & Kozhikode District, Kerala. It is inter alia, noted that the project comes under the Category B, 8(a) of Schedule

of EIA Notification 2006. No forest land is involved in the present project. The height of the proposed building is 59.70m and the total plot area of the proposed project is 78,268.98m<sup>2</sup> and the total built-up area is 1,45,000m<sup>2</sup>.

2. The proposal placed in 56<sup>th</sup> SEAC meeting held on 6<sup>th</sup> & 7<sup>th</sup> June 2016. Further to the intimation of SEAC, the proponent and engineer attended the meeting and the engineer made a power point presentation about the salient features of the project briefly. The Committee appraised the proposal based on Form 1, Form I A and conceptual plan. The Committee decided to DEFER the item for field visit and the sub-committee entrusted to specially look into the following aspects.

1. The aerial distance from the Malabar Wild life sanctuary to the project site.
2. Violation in the form of large scale excavations as is observed from the Google map of the area
3. Considering other massive developments noticed from the map is there a need for insisting on a EIA study.
4. 'Status of a portion of site classified as "nilam" in the documents.
5. Being an isolated property precaution to be taken against accidents like fire.

3. Site visit conducted on 23.6.2016 by subcommittee of SEAC and the proposal placed in 59<sup>th</sup> SEAC held on 11<sup>th</sup> & 12<sup>th</sup> July 2016. 59<sup>th</sup> SEAC remarked that this proposed project is in Kodenchery Village in Kozhikkode Taluk. Kodenchery Village is a notified ESA Village as per the Order No.F.No.1-4/2012-RE(Pt.), Government of India, MoEF dated 13.11.2013. In the para 9(c) of the said order building and construction projects of 20,000 m<sup>2</sup> area or above are prohibited. The present project involves construction of four buildings having a total built up area of 1,45,000 m<sup>2</sup>. Since this area far exceeds the permissible limit of construction in ESA Village the committee recommend to reject the proposal.

4. On 23-08-2016, the proponent submitted a representation to reconsider the proposal and has undertaken that "we are ready to fix the area of construction of each individual building to less than 20,000 sq.m and the area of the project to less than 1,50,000 sq.m and revise our plan accordingly." The proposal was considered in the 58<sup>th</sup> meeting of SEIAA held on 8<sup>th</sup> September 2016. The Authority found that the project is a category 8(b) project but appraised under 8(a) and referred the proposal to SEAC for reappraisal as the project comes under the category of 8(b)

5. The proposal was considered in the 63<sup>rd</sup> Meeting of SEAC held on 04<sup>th</sup> October, 2016. The SEAC committee remarked that only proposals for townships and area development covering an area more than 50 ha and or built up area more than 1,50,000 sq. m fall under such category. The present proposal is not such a project & hence it cannot be categorized as 8 (b). Hence the Committee decided not to change its earlier decision in the matter. The suggestion of the proponent to bring down the area of the individual buildings to less than 20000 sq. m will not serve the purpose as the total area of adjoining constructions will be far in excess of the limitations brought out in the 13.11.2013 Notification of MoEF.

6. The proposal was placed before the 61<sup>st</sup> SEIAA meeting held on 30-11-2016. The Authority noted that the present project involves construction of four buildings having a total built up area of 1, 45,000 m<sup>2</sup>. And hence it is appraised as Category 8(a). Since this area far exceeds the permissible limit of construction in ESA Village the Committee in its 59<sup>th</sup> meeting recommended to reject the proposal. In 61<sup>st</sup> SEIAA meeting, the Authority decided to accept recommendation of SEAC to reject the proposal as per the 59<sup>th</sup> & 63<sup>rd</sup> minutes of SEAC.

7. Sri. C Anwar Sadath, Director, Calicut Landmark Builders & Developers (India), Pvt Ltd. submitted a request on 06.05.2017 for reviewing the earlier decision of SEIAA to reject their application for EC. Proponent also informed that as per the Supreme court judgment dated 3.12.2016 in WP(C) 202 /2007 filed by T.N.Godavarman, Thirumulpad against Union of India, it has been clarified that townships with area below 1,50,000 sqmtrs should also obtain EC from SEIAA or MoEF. Calicut Landmark Builders & Developers (India), Pvt Ltd. has therefore submitted a petition to the Hon. Chief Minister to review the earlier decision of SEIAA to reject their application for EC. The proposal considered in 73<sup>rd</sup> SEIAA meeting held on 15.09.2017. Authority decided to obtain legal opinion in the matter from the Standing Counsel of NGT and Legal department of the State Government.

8. Meanwhile Environment department had forwarded the request of Sri.C.Anvar Sadath, Director, Calicut Landmark Builders & Developers (India) Pvt Ltd. to furnish the present status of the project. File had been placed before 98<sup>th</sup> SEIAA meeting held on 18<sup>th</sup> & 19<sup>th</sup> October 2019 and the authority decided to inform the proponent that the proposal was already rejected by SEIAA in its 61<sup>st</sup> meeting held on 30.11.2016, as the proposed project site falls

within the Ecologically Sensitive Area (ESA), and hence the proposal cannot be considered as per the existing norms of MoEF which prohibits such constructions in ESA to ensure the environmental stability of the region.

Hence letter had been issued to Sri. C. Anwar Sadath informing that their proposal cannot be considered as per the existing norms of MoEF as the proposed project site falls within the Ecologically Sensitive Area (ESA).

9. Sri. C. Anwar Sadath, the Director, Landmark builders submitted representations dated 30.10.2019 & 01/11/2019 with a request to reconsider their request for Environmental Clearance since their area is not falling under ESA land as per latest orders of MoEF and to give them a personal hearing to explain the facts. Accordingly they were invited for personal hearing.

10. Proponent along with RQP attended the hearing on 99<sup>th</sup> SEIAA meeting held on 21st November 2019 during which the proponent submitted the order F No.1/9/2018-ESZ dt.03.12.2018 of MoEF exempting certain villages in Kerala from ESA, as per which the survey nos of the proponents project area do not fall in ESA. Further the Village Officer Kodenchery has provided a Certificate dt. 25.06.2019 that the said survey nos do not fall in ESA area. SEAC has already appraised the proposal and EC was held up because of ESA issue.

Authority decided to issue EC for 7 years subject to the following specific conditions in addition to the general conditions.

- 1. Proponent shall attend all the observations made by SEAC during appraisals of the project.*
- 2. Activities relating to Corporate Environmental Responsibilities (2% of total project cost) shall be carried out leading to protection and promotion of environment including waste management in the project district as per OM F.No.22-65/2017-IA-III dt.01.05.2018 of MoEF & CC as directed by Director, Environment and supervised by District Collector.*
- 3. Provision shall be made for the housing of construction labour within the site with all necessary infrastructure and facilities such as fuel for cooking, mobile toilets, mobile STP, safe drinking water, medical health care, crèche etc. The housing may be in the form of temporary structures to be removed after the completion of the project (Circular No.J-11013/41/2006-IA.II(I) of GoI, MoEF dt.22.09.2008).*

11. For clarification regarding the observations made by SEAC during appraisals of the project, the proposal was placed in 100<sup>th</sup> SEIAA meeting held on 23<sup>rd</sup> & 24<sup>th</sup> December 2019. Authority decided to issue EC subject to the condition that the proponent shall attend all observations made by SEAC during appraisal of the project. Hence to issue EC immediately. SEAC shall carry out post EC appraisal within one month and make specific recommendations if any, which shall be carried out by the proponent.

12. In this circumstance, Authority is pleased to issue Environmental Clearance as per the EIA Notification 2006 for the proposed "Township" Project at Sy Nos. 15/1& 33/1 at Kodenchery Village, Kozhikode Taluk & Kozhikode District, Kerala by Sri Anwar Sadath, Director, M/s Calicut Landmark Builders & Developers (India) Pvt. Ltd. Landmark World, N.H.17 Bypass, Kozhikode, Kerala-673014, for seven years subject to the specific conditions in para 10 and 11 of this proceeding and the usual general conditions for projects other than mining appended hereto. Also the following green conditions should be strictly adhered to.

**Green Conditions.**

1. *Adequate rain water harvesting facilities shall be arranged for.*
2. *Technology and capacity of the STP to be indicated with discharge point (if any) of the treated effluent.*
3. *Effluent water not conforming to specifications shall not be let out to water bodies.*
4. *Maximum reuse of grey water for toilet flushing and gardening and construction work shall be ensured.*
5. *Dual plumbing for flushing shall be done.*
6. *Provisions for disposal of e-wastes, solid wastes, non-biodegradables and separate parking facility for the buildings shall be provided.*
7. *Generation of solar energy to be mandatory for own use and/or to be provided to the grid.*
8. *There shall be no compromise on safety conditions and facilities to be provided by the project proponent, which shall be ensured for occupation, regularisation or consent to operate.*

13. The Clearance will also be subject to full and effective implementation of all the undertakings given in the application form, all the environmental impact mitigation and management measures undertaken by the project proponent in the documents submitted to SEIAA, and the mitigation measures and waste management proposal as assured in the Form - 1 and Form-IA, Environment Management Plan as submitted. The assurances and clarifications given by the proponent in the application and related documents will be deemed to be part of these proceedings as conditions as undertaken by the proponent, as if incorporated herein.

14. Validity of this environmental clearance will be seven years from the date of issuance of this order, subject to earlier review in the event of non-compliance or violation of any of the conditions stipulated herein.

15. Compliance of the conditions herein will be monitored by Authority or its agencies and also by the regional office of the Ministry of Environment & Forests Government of India, Bangalore.

- I. Necessary assistance for entry and inspection should be provided by the project proponent and those who are engaged or entrusted by him to the staff for inspection or monitoring.
- II. Instances of violation if any shall be reported to the District Collector, Kozhikkode to take legal action under the Environment (Protection) Act 1986.
- III. The Half Yearly Compliance Report (HYCRs) with its contents of a covering letter, compliance report and environmental monitoring data has to be in PDF format merged into a single document. The email should clearly mention the name of the project, EC No and date, period of submission and to be sent to the Regional Office of MoEF & CC by email only at email ID [rosz.bng-mefcc@gov.in](mailto:rosz.bng-mefcc@gov.in). Hardcopy of HYCRs shall not be acceptable.
- IV. The given address for correspondence with the authorised signatory of the project is Sri Anwar Sadath, Director, M/s Calicut Landmark Builders & Developers (India) Pvt. Ltd., Landmark World, N.H.17 Bypass, Kozhikode, Kerala-673014)

  
SABITHA.S

Administrator, SEIAA

To,

Sri Anwar Sadath, Director,  
M/s Calicut Landmark Builders &  
Developers (India) Pvt. Ltd.  
Landmark World, N.H.17 Bypass,  
Kozhikode, Kerala-673014)

## **CHAPTER-5**

### **SITE PHOTOGRAPHS** **TOWER-1**







**TOWER-2**





**TOWER -3**





**TOWER 6**





## **CHAPTER-6**

**CONSTRUCTION OF GROUP HOUSING PROJECT AT RE-SURVEY NO. 15/1, 33/1, WARD NO. 21, KODENCHERY, PANCHAYATH, DISTRICT CALICUT, KERALA POINT-WISE COMPLIANCE OF STIPULATED ENVIRONMENTAL CONDITIONS/ SAFEGUARDS IN THE ENVIRONMENTAL CLEARANCE .F.No. 22-65/2017-IA.III DATED 1<sup>ST</sup> MAY, 2018**

Sl. No.	Conditions	Status of Compliance
<b>PART A - SPECIFIC CONDITIONS: Construction Phase:-</b>		
I	“Consent for Establishment” shall be obtained from Kerala State Pollution Control Board under Air and Water Act and a copy shall be submitted to the Ministry before start of any construction work at the site.	“Consent for Establishment” already obtained from Kerala State Pollution Control Board under Air and Water Act Consent PCB/RO/KKD/ICE/09/2015 dated 17.06.2015 and the Application for renewal in process. a copy is enclosed as <b>Annexure-I</b>
II	Provision shall be made for the housing of construction labour within the site with all necessary infrastructure and facilities such as fuel for cooking, mobile toilets, mobile STP, safe drinking water, medical health care, crèche etc. The housing may be in the form of temporary structures to be removed after the completion of the project.	For the housing of construction labour within the site (peak time maximum 100 workers) all necessary infrastructure and facilities such as canteen, power, toilets, safe drinking water etc., is made available. Provided soak pit and cooking gas facility within the site. We have been appointed a doctor to provide proper guidance and support to maintain workers health and is regularly conducting various health related camps the same is enclosed as <b>Annexure-II.</b>

III	A first aid room will be provided in the project both during construction and operation of the project.	First Aid room has being provided in the construction site and it will be kept for operation phase. Details is enclosed as <b>Annexure- III.</b>
IV	All the topsoil excavated during construction activities should be stored for use in horticulture/ landscape development within the project site.	The top soil excavated was being stored within the project site for use in landscape during the later stages of the development and is duly being used for the landscaping work. Details is enclosed as <b>Annexure- IV.</b>
IV	Disposal of muck during construction phase should not create any adverse effect on the neighboring communities and be disposed taking the necessary precautions for general safety and health aspects of people, only in approved sites with the approval of competent authority.	Precautions are being taken while disposing muck during construction phase so it will not create any adverse effect on the neighboring communities.
VI	Soil and ground water samples will be tested to ascertain that there is no threat to ground water quality by leaching of heavy metals and other toxic contaminants.	Testing of soil and Ground water analysis is being done from time to time and no signs of contamination have been found. Water Analysis reports  It is attached as <b>Annexure- V.</b>
VII	Construction spoils, including bituminous material and other hazardous materials, must not be allowed to contaminate watercourses and the dump sites for such material must be secured so that they should not leach into the ground water.	Construction spoils are used for leveling that it on the middle of the site. Our hot mix plants are located far away from site from which the mixes are prepared and transported to site and using mechanical devices and pavers for surfacing roads. So the contamination in this



		manner can be ruled out. Plant showing photographs are enclosed as <b>Annexure- VI</b> .
VIII	Any hazardous waste generated during construction phase, should be disposal off as per applicable rules and norms with necessary approval of the Kerala State Pollution Control Board.	Only spent oil of D.G. sets is hazardous waste generated during construction phase which is disposed of as per applicable Rules & norms to sold to approved recyclers.
IX	The diesel generator sets to be used during construction phase should be low sulphur diesel type and should conform to Environment (Protection) Rules prescribed for air and noise emission standards.	Low Sulphur Diesel is being used for the DG set (2 nos 125 KVA. 1 nos 400 KVA with acoustic system) during construction phase. It is attached as <b>Annexure- VII</b> .
X	The diesel required for operating DG sets shall be stored in underground tanks and if required, clearance from Chief Controller of Explosives shall be taken.	The quantity of diesel required during construction phase is very less and during operation phase it will be stored in underground tanks if required.
XI	Vehicles hired for bringing construction material to the site should be in good condition and should have pollution check certificate and should conform to applicable air and noise emission standards and should be operated only during non-peak hours.	It is being ensured that vehicles(Max 15 vehicles in the peak period) hired for bringing construction material at site are in good condition and with valid “pollution under check” (PUC) certificate and conform to applicable air and noise emission standards and are operated only during non-peak hours. Pollution Under Check certificate for the vehicles are attached as <b>Annexure – VIII</b>
XII	Ambient noise levels should conform to residential standards both during day and night. Incremental pollution loads on the	Ambient noise levels will conform to standards both during day and night. Incremental pollution loads on the ambient air and noise

	ambient air and noise quality should be closely monitored during construction phase. Adequate measures should be made to reduce ambient air and noise level during construction phase, so as to conform to the stipulated standards by CPCB/KSPCB.	quality is being closely monitored during construction phase. Adequate measures are being made to reduce ambient air and noise level during construction phase, so as to conform to the stipulated standards. Noise levels & air monitoring reports are attached as <b>Annexure – IX.</b>
XIII	Fly ash should be used as building material in the construction as per the provisions of Fly Ash Notification of September, 1999 and amended as on 27 <sup>th</sup> August, 2003. (The above condition is applicable only if the project site is located within the 100 km of Thermal Power Stations)	Since the fly ash is not common in this area. We are unable to use the fly ash material as construction material.
XIV	Ready mixed concrete must be used in building construction.	Ready mixed concrete is only being used in building construction. Photos of RMC at site attached as <b>Annexure- VI</b>
XV	Storm water control and its re-use as per CGWB and BIS standards for various applications.	We will follow the CGWB and BIS standards and will install Rain Water harvesting pits and waste water will be treated in a STP and treated water will be reused as much as possible in the project premises.
XVI	Water demand during construction should be reduced by use of premixed concrete, curing agents and other best practices referred.	Water demand is being reduced in the construction phase to the level possible. In the monsoon season no extra water needs to be used for curing due to the continuous rains
XVII	Permission to draw ground water shall be obtained from the Competent Authority	Application has been filled for withdrawal of water for the construction and operation

	prior to construction / operation of the project.	phase. A copy of the same is enclosed as <b>Annexure – X.</b>
XVIII	Separation of grey and black water should be done by the use of dual plumbing line for separation of grey and black water.	Dual plumbing system has been installed for meeting chiller, horticulture and flushing needs, Dual plumbing plan is enclosed as <b>Annexure- X.</b>
XIX	Fixtures for showers, toilet flushing and drinking should be of low flow either by use of aerators or pressure reducing devices or sensor based control.	Water efficient fixtures will only be used and the water fixtures that come under tenant’s scope will be insisted.
XX	Use of glass may be reduced by up to 40% to reduce the electricity consumption and load on air-conditioning. If necessary, use high quality double glass with special reflective coating in windows.	High quality double glass with special reflective coating is being used in the building.
XXI	Roof should meet prescriptive requirement as per Energy Conservation Building Code by using appropriate thermal insulation material to fulfill requirement.	Proper thermal insulation material for roof will be provided to reduce energy requirement and ECBC norms will be adhered to.
XXII	Opaque wall should meet prescriptive requirement as per Energy Conservation Building Code which is proposed to be made mandatory for all air-conditioned spaces while it is aspirational for non-air conditioned spaces by use of appropriate thermal insulation material to fulfill requirement.	ECBC norms will be adhered to.
XXIII	The approval of the competent authority shall be obtained for structural safety of the building due to earthquake, adequacy of	The structural Designer has considered all these aspects prior to the designing and has done structural design to with stand the earth

	<p>firefighting equipments, etc. as per National Building Code including protection measures form lightening etc.</p>	<p>quake. A copy of the structural certificate is <b>enclosed as Annexure- XI</b>. Approval has been taken from the Fire department vide letter No. F2-13199/16 dated 17.10.2016 Lightning Arrestors will be put up on the roof of the buildings. Fire NOC copy is enclosed as <b>Annexure- XII</b>.</p>
XXIV	<p>Regular supervisions of the above and other measures for monitoring should be in place all through the construction phase, so as to avoid disturbance to the surroundings.</p>	<p>Proper barricading is done so as to avoid disturbance to the surroundings and supervisors are there to supervise the project work and control the impact on environment during construction phase. Photos of the same attached as <b>Annexure- XII</b>.</p>
XXV	<p>Under the provisions of environment (protection) Act, 1986, legal action shall be initiated against the project proponent if it was found that construction of the project has been started without obtaining environmental clearance.</p>	<p>Environmental Clearance letter has been obtained from SEIAA Kerala 73/2019 DATED 28<sup>th</sup> DECEMBER, 2019 Copy of Environmental Clearance letter is enclosed in <b>Chapter-6</b>.</p>
<p><b><u>II. OPERATION PHASE</u></b></p>		
I	<p>The installation of the Sewage treatment Plant (STP) should be certified by an independent expert and a report in this regard should be submitted to the ministry before the project is commissioned for operation. Treated affluent emanating from STP shall be recycled/reused to the maximum extent possible. Treatment of 100% grey water by decentralized treatment</p>	<p>The STP will be installed for the treatment of sewage generated to the prescribed standards including odor and treated effluent will be recycled to the maximum extent possible to achieve Zero Discharge. In case treated effluent is to discharge separately during monsoon period the effluent will conform to the norms of Kerala State Pollution Control Board.</p>

	<p>should be done. Discharge of unused treated effluent shall conform to the norms and standards of the Kerala State Pollution Control Board. Necessary measure should be made to mitigate the odor problem from STP.</p>	<p>“Consent for Operate” already obtained from Kerala State Pollution Control Board under Air and Water Act Consent PCB/RO/KKD/ICE/09/2015 dated 16.06.2018 and the Renewal is in Process.</p>
II	<p>The solid waste generated should be properly collected and segregated. Wet garbage should be composted and dry/ insert solid waste should be disposed off to be approved sites for land filling after recovering recyclable material.</p>	<p>During operation phase solid waste generated will be properly collected &amp; segregated. Wet garbage will be sent for composting and dry/inert solid waste would be disposed off to approved sites for agricultural purpose/for land filling after recovering recyclable material.</p>
III	<p>Diesel power generating sets proposed as source of backup power for elevators and common area illumination during operation phase should be of enclosed type and conform to rules made under the Environment (Protection) Act, 1986. The height of stack of DG sets should be equal to the height needed for the combined capacity of all proposed DG sets. Use low sulphur diesel. The location of the DG sets may be decided with in consultation with Kerala State Pollution control Board.</p>	<p>During operation phase DG sets will be installed in case of power failure. These will be of the enclosed type and will also be provided with adequate stack height as per CPCB norms. In addition these DG sets will be run on low sulphur diesel only (Sulphur content &lt; 0.25%)</p>
IV	<p>Noise should be controlled to ensure that it does not exceed the prescribed standards. During night time the noise levels measured at the boundary of the building shall be restricted to the permissible levels to comply with the prevalent regulations.</p>	<p>Noise level will be controlled within and at the boundaries of the project ensuring compliance to regulatory norms</p>

V	The green belt of the adequate width and density preferably with local species along the periphery of the plot shall be raised so as to provide protection against particulates and noise.	Green belt of adequate width and density being provided with local species along the periphery of the plot for the provide protection against particulates and noise.
VI	Weep holes in the compound walls shall be provided to ensure natural drainage of rain water in the catchments area during the monsoon period.	Natural drainage of rain water, during the monsoons will be aided by provision of weep holes in the compound walls.
VII	Rain water harvesting for roof-off and surface run-off, as plan submitted should be implemented. Before recharging the surface run-off, pre-treatment must be done to remove suspended matter, oil and grease. The borewell for rain water recharging should be kept at least 5 mts.above the highest ground water table.	Rain water Harvesting as per plan for roof run-off and surface run off will be implemented. Suspended matter, oil and grease will be removed by treatment before recharging with surface run-off. The bore well for recharge will be kept at least 5 mts. above the highest ground water table.
VIII	The ground water level and its quality should be monitored regularly in consultation with Central Ground water Authority.	Yes, time to time ground water level and its quality will be monitored regularly in consultation with CWRDM.
IX	Traffic congestion near the entry and exist points from the roads adjoining the proposed project site must be avoided. Parking should be fully internalized and no public space should be utilized.	Parking will be completely internalized and no public space will be utilized. Care will be taken to ensure that there is no traffic congestion at the entry and exit points.
X	A report on the energy conservation measures confirming to energy conservation norms finalize by Bureau of Energy Efficiency should be prepared incorporating	Report on energy conservation measure conforming to energy conservation norms finalized by BEE will be prepared, which will include details of building materials and

	details about building materials & technology; R & U factors etc. and submit to the Ministry in three months time.	technology, R & U factors etc and submitted to the Ministry.
XI	Energy conservation measures like installation of CFLs/TFLs for the lighting the areas outside the building should be integral part of the project design and should be properly collected and disposed off/sent for recycling as per the prevailing guidelines/rules of the regulatory authority to avoid mercury contamination. Use of solar panels may be done to the extent possible	Energy conservation measures like installation of CFLs/LEDs for lighting the areas outside the building would be integral part of the project design and would be in place before project commissioning. Used CFLs & LEDs would be properly collected and sent for recycling as per the guidelines of the regulatory authority to avoid Mercury contamination. Solar energy is used for street lighting.
XII	Adequate measure should be taken to prevent odor problem from solid waste processing plant and STP.	Separate secondary processing area is identified and a green muffler zone will be created around it so as to prevent odor problem from solid waste processing plant as also from the STP.
XIII	The building should have adequate distance between them to allow movement of fresh air and passage of natural light, air and ventilation.	Buildings will have adequate distance between them to allow movement of fresh air and passage of natural light, air and ventilation.
<b>PART – B. <u>GENERAL CONDITIONS</u></b>		

I	The project proponent shall also submit six monthly reports on the status of compliance of the stipulated EC conditions including results of monitored data (both in hard copies as well as by e-mail) to the respective Regional Office of MOEF, the respective Zonal Office of CPCB and the SPCB.	We will submit six month report on the status of compliance of the stipulated EC conditions including results of monitored data (both in hard copies as well as by e-mail) to the respective Regional Office of MOEF, the respective Zonal Office of CPCB and the SPCB.
2	Officials from the Regional Office of MoEF, Bangalore who would be monitoring the implementation of environmental safeguards should be given full cooperation, facilities and documents/data by the project proponents during their inspection. A complete set of all the documents submitted to MoEF should be forwarded to the CCF, Regional Office of MoEF, Bangalore.	A complete set of all the documents had submitted to Regional Office of MoEF, CCF, Bangalore.
3	In the case of any change(s) in the scope of the project, the project would require a fresh appraisal by this Ministry.	Agreed.



4	The Ministry reserves the right to add additional safeguard measures subsequently, if found necessary, and to take action including revoking of the environment clearance under the provisions of the Environmental (Protection) Act, 1986, to ensure effective implementation of the suggested safeguard measures in a time bound and satisfactory manner.	Agreed, the Ministry reserves the right to add additional safeguard measures subsequently, if found necessary, and to take action including revoking of the environment clearance under the provisions of the Environmental (Protection) Act, 1986, to ensure effective implementation of the suggested safeguard measures in a time bound and satisfactory manner.
5	All other statutory clearances such as the approvals for storage of diesel from Chief Controller of Explosives, Fire Department, Civil Aviation Department, Forest Conservation Act, 1980 and Wildlife (Protection) Act, 1972 etc. shall be obtained as applicable by project proponents from the respective competent authorities.	Agreed
6	These stipulations would be enforced among under the provisions of Water (Prevention and Control of Pollution) Act, 1974, the Air (Prevention and Control of Pollution) Act, 1981, the Environment (Prevention) Act, 1986, the Public Liability (Insurance) Act. 1991 and EIA Notification, 2006	As per the Water (Prevention and Control of Pollution) Act, 1974, the Air (Prevention and Control of Pollution) Act, 1981 we have already obtained CTE from Kerala State Pollution Control Board and since our project build up area more than 20,000 sqm we have already obtained Environmental Clearance from MoEF as per EIA Notification, 2006 and its amendments.

7	<p>The project proponent should advertise in at least two local newspapers widely circulated in the region, one of which shall be in the vernacular language informing that the project has been accorded Environmental Clearance and copies of clearance letters are available with the Kerala Pollution Control Board and may also be seen on the website of the Ministry of Environment and Forests, at <a href="http://www.envfor.nic.in">http://www.envfor.nic.in</a>. The advertisement should be made within 10 days from the date of receipt of the clearance letter and a copy of the same should be forwarded to the Regional office of this Ministry at Bangalore</p>	<p>The project proponent had already advertised in two local newspapers a copy of the same had been submitted to the Regional office of this Ministry at Bangalore. A copy of advertisement is enclosed as <b>Annexure-XIV</b>.</p>
8	<p>Environmental clearance is subject to final order of the Hon'ble Supreme Court of India in the matter of Goa Foundation v/s. Union of India in Writ Petition (Civil) No.460 of 2004 as may be applicable to this project.</p>	<p>Agreed</p>

9	<p>A copy of the clearance letter shall be sent by the proponent to concerned Panchayat, ZillaParisad/Municipal Corporation, Urban Local Body and the Local NGO, if any from whom suggestions/representations, if any, were received while processing the proposal. The clearance letter shall also be put on the website of the company by the proponent.</p>	Agreed
10	<p>The proponent shall upload the status of compliance of the stipulated EC conditions, including results of monitored data on their website and shall update the same periodically. It shall simultaneously be sent to the Regional Office of MoEF, the respective Zonal office of CPCB and the SPCB. The criteria pollutant levels namely; SPM, RSPM, SO2, NOX (ambient levels as well as stack emissions) or critical sectoral parameters, indicated for the project shall be monitored and displayed at a convenient location near the main gate of the company in the public domain.</p>	Compliance report is being submitted to Regional Office of MoEF and SPCB.

11	The environmental statement for each financial year ending 31st March in Form-V as in mandated to be submitted by the project proponent to the concerned State Pollution Control Board as prescribed under the Environment (Protection) Rules, 1986, as amended Subsequently, shall also be put on the website of the company along with the status of compliance of EC conditions and shall also be sent to the respective Regional Offices of MoEF by e-mail.	The environmental statement for each financial year ending 31st March in Form-V will be submitted.
----	---	--

<b>Sl. No.</b>	<b>ANNEXURES</b>	<b>Page No</b>
<b>I.</b>	Copy of Consent for Establishment from Kerala State Pollution Control Board under Air and Water Act	38
<b>II.</b>	Photographs showing conducting various health related camps for workers	39-40
<b>III</b>	Photographs showing first aid room	41-42
<b>IV</b>	Photo showing the topsoil excavated used for landscape development	43
<b>V.</b>	Soil and Water testing report	44-52
<b>VI</b>	Photograph showing ready mixed concrete plant	56
<b>VII</b>	Photographs showing diesel generator	57-59
<b>VII.</b>	Copy of Pollution Under Check certificate for the vehicles	60
<b>IX.</b>	Noise levels & air monitoring reports	61-63
<b>X</b>	Dual plumbing plan	64-65
<b>XI</b>	Copy of the structural certificate	66
<b>XII</b>	Copy of Fire NOC	67
<b>XIII</b>	Photographs showing proper barricading to avoid disturbance to the surroundings	68
<b>XIV</b>	Copy of newspaper advertisement	69

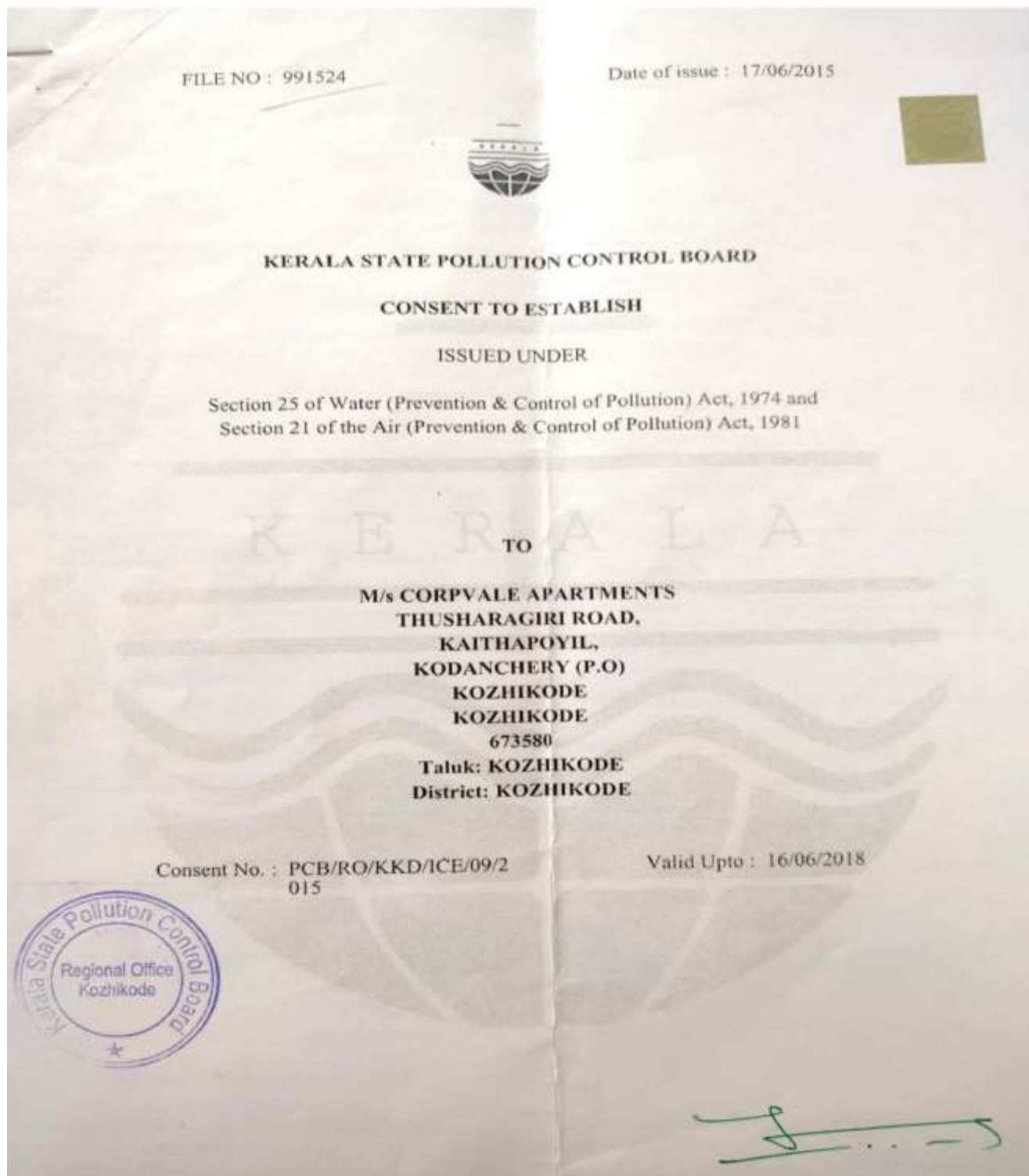

(NOTE:IS PROCESSING FOR RENEWAL)













## REPORT ON SOIL INVESTIGATION



<b>PROJECT</b>	: Proposed Land Mark Village Residential Apartment Building, at Thamarassery.
<b>CLIENT</b>	: M/s.OZO Mall Kozhikode.
<b>CONSULTANT(Foundation)</b>	: Prof. A. K. Abdul Kalam, M.Tech. Civil Engineering Consultant, Aluva.

## **ACE FOUNDATIONS CALICUT**

2/858, E.K.Complex, Near Eranhipalam Post Office, Calicut - 673 006

Ph: 0495-2768293, Mobile: 098460 86524

E-mail: acefoundationscalicut@gmail.com

**REPORT ON SOIL INVESTIGATION CARRIED OUT FOR  
THE PROPOSED LAND MARK VILLAGE RESIDENTIAL  
APARTMENT BUILDING AT THAMARASSERY,  
CALICUT.**

**1. SCOPE OF WORK**

The scope of the project envisages sub-surface investigation carried out for the purpose of the design of foundation for the proposed Building. The scope of the work also involves executing **Three Bore Holes** with related field tests, collection of disturbed SPT Soil Samples.

**2. CODES AND STANDARDS**

All works were carried out as per given specification. Where not specified, the latest relevant IS codes were followed.

**3. PURPOSE**

The purpose of the proposed Geo-Technical Investigation was to obtain the following:-

- a. To perform the required field investigation including soil boring with related field tests within the bore hole, collecting samples.
- b. To determine the type, extent to the sub-surface material upto **Hard strata**.

**4. FIELD WORKS / TESTS**

The Field work consists of:-

- a. Executing **Three Bore Hole** upto **Hard strata**.
- b. Obtaining disturbed soil samples and finding out SPT 'N' values.

## 5 . PROGRAMME OF INVESTIGATION

Keeping in view of the type of structure and loading pattern **Three Bore Hole** was proposed. The details of the boreholes are attached duly showing the approximate dimensions with respect to the site. (Site Plan).

## 6. PROCEDURE

The Boreholes were executed using **Rotary Drilling** method. Circulation of bentonite slurry was used for advancing the boreholes and stabilizing the side. Casing pipes were introduced to protect the first few meters. Standard penetration tests were conducted at regular intervals and also at points where change of strata was observed. Representative samples were collected and sent **BH - 2** for laboratory analysis. Foundation recommendation obtained from structural consultant.

## 7. LABORATORY INVESTIGATION

Laboratory tests consists of the following:-

- a) Physical identification of soil
- b) Determination of natural water content.
- c) Specific Gravity
- d) Atterberg's limit (Liquid limit and plastic limit)
- e) Mechanical analysis of finding sand, clay and soil fractions.

\*\*\*\*\*

**SOIL REPORT**

25-02-2020

**Introduction**

M/s. ACE FOUNDATIONS CALICUT, Calicut has conducted soil investigation for a 20 storied building (Landmark Village Residential Building ) at Tamarassery, Calicut for M/s. OZO Mall, Calicut. They have taken 3 bore holes up to hard strata using rotary drill. Standard penetration tests were conducted at regular intervals and soil samples were taken from these depths. These samples were analysed in M/s. Geo Engineering Lab, Koonammavu, Kochi for identification and soil classification.

**Soil Profile**

In BH1, soil up to 0.9m depth is a lateritic fill followed by gravely soil up to 1.7m depth with N-value 11. From 1.7m to 5.8m it is sand with silty clay and N-value varies from 39 to 48. Soft rock is met at 5.8m, hard rock at 6.2m and BH is terminated at 8.2m. In BH2, soil up to 1.4m depth is silty clay with sand and gravel and N-value is 9. From 1.4m to 2.8m it is silty clay with sand and gravel and N-value is 40. From 2.8m to 4.1m it is sand with silt and clay and N-value is 46. From 4.1m to 5.6m it is silty clay with sand and gravel and N-value is 34. From 5.6m to 6.4m it is sand with silt and clay and N-value is >50. Soft rock is met at 6.4m, hard rock at 6.7m and BH is terminated at 8.7m depth. In BH3, hard rock is met at 7.4m and BH is terminated at 9.4m.

**Recommendation**

Bored cast in situ end bearing reinforced concrete piles by DMC method is recommended. Pile should penetrate in to hard rock ( depth varies from 6.2m to 7.4m) by a minimum of 30cm. Safe structural strength of concrete can be taken as pile capacity. It is recommended to limit contact pressure at pile tip to 40kg/cm<sup>2</sup>.

Following pile capacities are recommended,

Pile dia (cm)	Pile capacity (tons)
50cm	78t
60cm	113t
70cm	153t
80cm	200t
100cm	314t

Pile capacities are to be verified by pile load test.

This recommendation is based on BH chart & test results presented to me by M/s. ACE FOUNDATIONS CALICUT, Calicut. At the time of boring for piles if any change is observed in soil stratification, it should be reported to a Geo Technical Engineer. The recommendation made here is based on the bore holes chart presented to me & my own experience in this field & is to be exempted from any legal action from any party.

Prof. Abdul Kalam, M.Tech  
Mobile:-9846144957

Prof. A.K. ABDUL KALAM; M.Tech.  
(Civil Engineering Consultant)  
Palm Lands, Temple Road,  
BANK JN, ALUVA-683 108

  
Prof. A.K. ABDUL KALAM; M.Tech.  
(Civil Engineering Consultant)  
Palm Lands, Temple Road,  
BANK JN, ALUVA-683 108

## ACE FOUNDATIONS CALICUT CALICUT

<b>PROJECT</b> : Proposed Residential building <b>SITE</b> : Thamarssery, Calicut. <b>BORE HOLE NO.</b> : 1 <b>TYPE OF BORING</b> : Rotary Drilling	1/1	<b>DATE OF COMMENCE</b> : 09-02-2020 <b>DATE OF COMPLETION</b> : 09-02-2020 <b>GROUNDWATER LEVEL</b> : Not met with
--	-----	---

### BORE LOG CHART & DATA SHEET

Depth in Meter	Soil Profile	Visual Description of Soil	Thickness of Layers (M)	Standard Penetration Test Data				Graph of 'N' Value					Remarks			
				Depth (m)	15	30	40	'N' Value	10	20	30	40		50	>50	
0.00		Filled lateritic soil (Brown)	0.90													
0.90		Gravelly soil (Brown)	0.80	1.00	2	4	7	11								
1.70		Sand with silty clay (Y/brown)	4.10	2.00	7	17	22	39								
				3.00	11	21	27	48								
				4.50	9	18	23	41								
5.80				Soft rock (W/grey)	0.40	5.80	SPT Rebounded w/o sample Soft rock cleared with TC bit									
6.20		Hard rock (Grey)	2.00	Hard rock boring done with D/bit I lift from 6.20 to 7.20m Rec--36cm II lift from 7.20 to 8.20m Rec--57cm												
8.20				Bore hole terminated at 8.20 m depth												

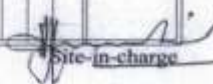
  
 Site-in-charge



## ACE FOUNDATIONS CALICUT CALICUT

<b>PROJECT</b> : Proposed Residential building <b>SITE</b> : Thamarssery, Calicut. <b>BORE HOLE NO.</b> : 2 <b>TYPE OF BORING</b> : Rotary Drilling	1/1	<b>DATE OF COMMENCE</b> : 11-02-2020 <b>DATE OF COMPLETION</b> : 11-02-2020 <b>GROUND WATER LEVEL</b> : Not met with
--	-----	--

### BORE LOG CHART & DATA SHEET

Depth in Meter	Soil Profile	Visual Description of Soil	Thickness of Layers (M)	Standard Penetration Test Data				Graph of 'N' Value					Remarks		
				Depth (m)	15	30	40	'N' Value	10	20	30	40		50	>50
0.00		Silty clayey sand with lateritic gravel (Brown)	1.40												
1.40		Silty clayey sand with lateritic gravel (Y/Brown)	1.40	1.00	2	3	6	9							
2.80		Sand with silty clay (Y/brown)	1.30	2.00	11	16	24	40							
4.10		Silty clayey lateritic gravelly sand (Brown)	1.50	3.00	9	19	27	46							
5.60		Sand with silty clay (Golden yellow)	0.80	4.50	10	16	18	34							
6.40		Soft rock (W/grey)	0.30	6.00	15	28	22	>50							(Bal-11cm)
6.70		Hard rock (Grey)	2.00	6.40	SPT Rebounded w/o sample Soft rock cleared with TC bit										
8.70		Bore hole terminated at 8.70 m depth			Hard rock boring done with D/bit I lift from 6.70 to 7.70m Rec-38cm II lift from 7.70 to 8.70m Rec-54cm										

  
 Site in charge

## ACE FOUNDATIONS CALICUT CALICUT

<b>PROJECT</b> : Proposed Residential building <b>SITE</b> : Thamarssery, Calicut. <b>BORE HOLE NO.</b> : 3 <b>TYPE OF BORING</b> : Rotary Drilling	<b>DATE OF COMMENCE</b> : 11-02-2020 <b>DATE OF COMPLETION</b> : 12-02-2020 <b>GROUNDWATER LEVEL</b> : Not met with
--	---

1/1

### BORE LOG CHART & DATA SHEET

Depth in Meter	Soil Profile	Visual Description of Soil	Thickness of Layers (M)	Standard Penetration Test Data				Graph of 'N' Value					Remarks			
				Depth (m)	15	30	40	'N' Value	10	20	30	40		50	>50	
0.00		Gravelly soil	0.70													
0.70		White boulder	0.20	0.70	SPT Rebounded w/o sample Removed by D/bit											
0.90		Gravelly soil	0.30	1.00	3	>50	-	>50							(Bal-28cm)	
1.20		White boulder	0.25	1.20	SPT Rebounded w/o sample Removed by D/bit											
1.45		Sand with silty clay (Y/brown)	2.75	2.00	22	39	11	>50							(Bal-11cm)	
				3.00	14	21	24	45								
4.20				Silty clayey lateritic gravelly sand(Brown)	1.20	4.50	9	20	26	46						
5.40		Sand with silty clay (Golden yellow)	1.50	6.00	>50	-	-	>50							(Bal-32cm)	
6.90		Soft rock (W/grey)	0.50	6.90	SPT Rebounded w/o sample Soft rock cleared with TC bit											
7.40		Hard rock (Grey)	2.00		Hard rock boring done with D/bit I lift from 7.40 to 8.40m Rec-44cm II lift from 8.40 to 9.40m Rec-49cm											
9.40				Bore hole terminated at 9.40 m depth												

Site-in-charge



BORE HOLE NO : 2		PROJECT : Proposed Land Mark Village Residential Apartment Building @ Thamarassery, Calicut.		JOB NO : GEL/312/2018-19													
DEPTH IN MTR : 8.70 m		CLIENT : M/s. OZO Mail, Calicut.		DATE OF BORING : 11-02-2020													
WATER LEVEL : NOT MET WITH		SHEET NO : 1		TYPE OF BORING : ROTARY													
SHEET NO : 1		TEST RESULTS															
N° VALUE	DEPTH IN MTR	SAMPLE NO	TYPE OF SAMPLE	SOIL DESCRIPTION	CLASSIFICATION IS	GRAIN SIZE ANALYSIS				ATTERBERG'S LIMIT			SHEAR PARAMETERS				
						GRAVEL %	SAND %	SILT %	CLAY %	SHELL	LIQUID LIMIT	PLASTIC LIMIT	PLASTICITY INDEX	NATURAL WATER CONTENT	SPECIFIC GRAVITY	TEST METHOD	C (KG/CM <sup>2</sup> )
9	1.00	SPT-1	D5	SILTY CLAYEY SAND WITH LATERITIC GRAVEL (BROWN)	SC	11	54	15	20								
40	2.00	SPT-2	D5	SILTY CLAYEY SAND WITH LATERITIC GRAVEL (YELLOW/BROWN)	SC	17	45	16	21								
46	3.00	SPT-3	D5	SAND WITH SILTY CLAY (YELLOW/BROWN)	SC	6	48	19	27	20	16	14					
34	4.50	SPT-4	D5	SILTY CLAYEY LATERITIC GRAVELLY SAND (BROWN)	SC	22	42	18	29								
>50	6.00	SPT-5	D5	SAND WITH SILTY CLAY (GOLDEN YELLOW)	SC	0	52	22	26								
	6.40	SPT REBOUNDED		SOFT ROCK													
	6.70			HARD ROCK													

NOTE: Samples were supplied to us by the client. M.C. Density & shear Test of SPT Samples are done on Remoulded Specimens



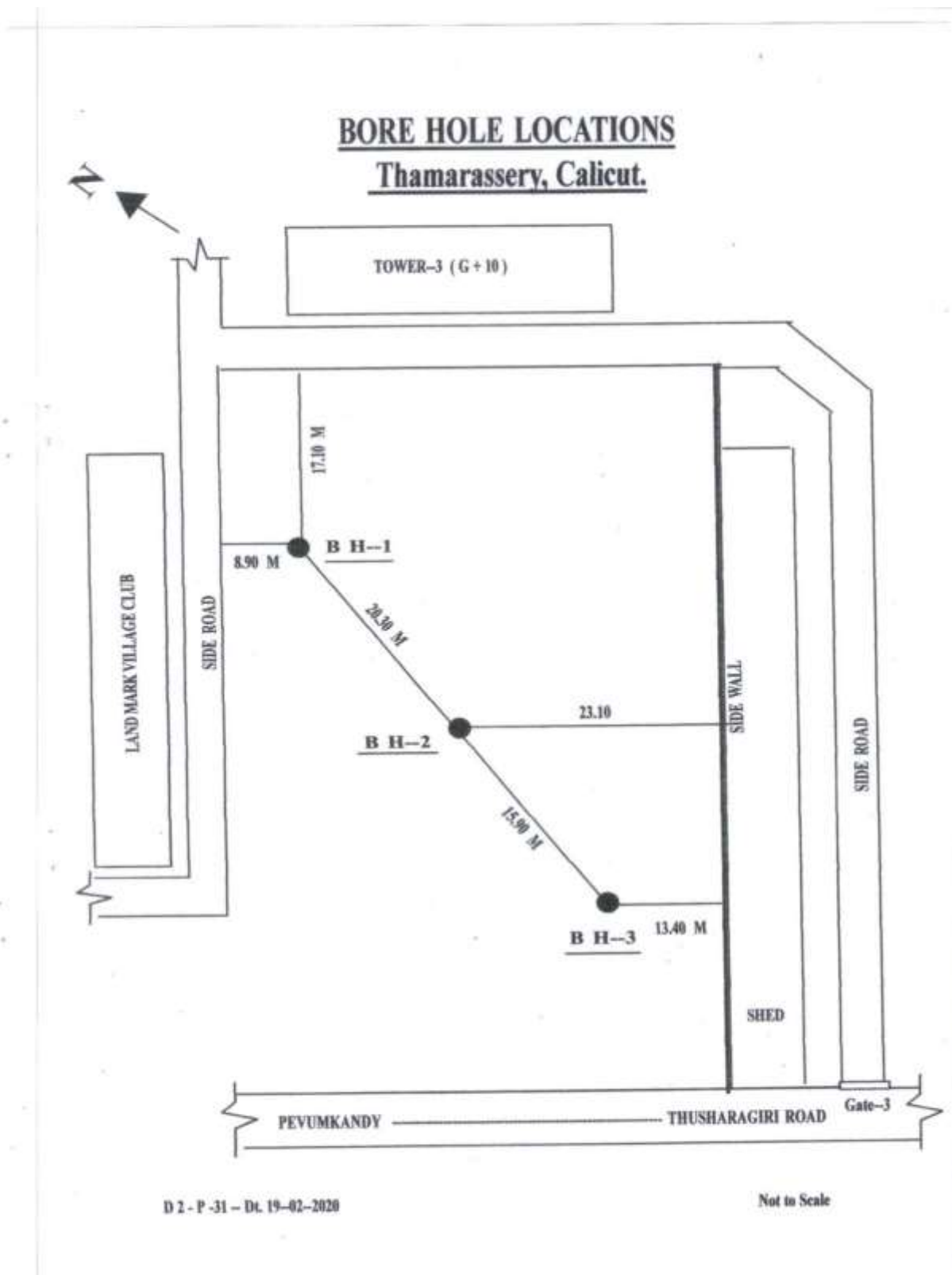



KERALA STATE  
POLLUTION CONTROL BOARD  
APPROVED LABORATORY

**Analysis Report**

AR No: AR /ABL/1214/ 2022

Date: 21/03/2022

Name: LAND MARK KNOWLEDGE CITY		Date & Time of sample collection: 18/03/2022	
Mob:		Sample collected by : Client	
Email:		Sample delivered by : Client	
Address: CALICUT		Date & Time of delivery : 18/03/2022, 02.50 PM	
Source of Sample: OPEN WELL WATER		Sample received by : Lab Analyst	
Sample container: Polythene bottle		Sample condition : Fit for analysis	
Type of Test	Chemical <input checked="" type="checkbox"/>	Microbiological <input checked="" type="checkbox"/>	Period of Analysis : 18/03/2022- 21/03/2022

Sl No	Parameter	Unit	Test method APHA	Results	Acceptable limit IS 10500
<b>Physical Examination</b>					
1	Colour	Hazen	2120 B	< 1	5
2	Taste and odor		2160 A	Agreeable	Agreeable
3	Electrical conductivity	µS/cm	2510 B	135	50-800
4	Turbidity	NTU	2130 B	20	5
5	Total Dissolved solids	mg/L	2540 C	64	500
<b>Chemical Examination</b>					
6	pH	-	4500 H <sup>+</sup> B	6.3	6.5 - 8.5
7	Total Alkalinity	mg/L	2320 B	34	200
8	Total Hardness as CaCO <sub>3</sub>	mg/L	2340 C	47	200
9	Calcium Hardness as CaCO <sub>3</sub>	mg/L	3500 Ca B	10	
10	Magnesium Hardness as CaCO <sub>3</sub>	mg/L	3500 Mg B	37	
11	Calcium	mg/L	3500 Ca B	4	75
12	Magnesium	mg/L	3500 Mg B	8.99	30
13	Chloride	mg/L	4500 Cl <sup>-</sup> B	14.01	250
14	Sulphate	mg/L	4500 SO <sub>4</sub> E	104.25	200
15	Ammonia	mg/L	4500 NH <sub>3</sub> F	BDL	0.5
16	Iron	mg/L	3500 Fe B	3.14	0.3
<b>Bacteriology</b>					
17	Total Coliform	cfu/100ml	9222 B	NIL	Nil / 100ml
18	Faecal Coliform	cfu/100ml	9221 E	NIL	Nil / 100ml

The report is of the sample tested only and shall not be reproduced except in full.

Remarks: pH below the acceptable limit. Turbidity is above the acceptable limit  
Iron present and above the acceptable limit.  
Coliforms absent.  
BDL: Below Detection Level



*[Signature]*  
Authorized signatory

**AMPLICON BIOLABS**  
Room No. 17, Park Centre, KINFRA, Kakkanchery,  
Calicut University P.O, Malappuram 673 635, Kerala  
☎ 0494 240 77 77  
✉ ampliconbiolabs@gmail.com 🌐 www.ampliconbiolabs.com

Approval No. PCB/CL/RL/4/2009



KERALA STATE POLLUTION CONTROL BOARD APPROVED LABORATORY

Analysis Report

AR No: AR /ABL/1216/ 2022

Date: 21/03/2022

Name: LAND MARK	Date & Time of sample collection: 18/03/2022
Mob:	
Email:	
Address: Knowledge city, Calicut	Sample collected by : Client
	Sample delivered by : Client
	Date & Time of delivery : 18/03/2022, 02.50 PM
Source of Sample: BORE WELL -2	Sample received by : Lab Analyst
Sample container: Polythene bottle	Sample condition : Fit for analysis
Type of Test	Period of Analysis : 18/03/2022- 21/03/2022
Chemical <input checked="" type="checkbox"/>	
Microbiological <input checked="" type="checkbox"/>	

Sl No	Parameter	Unit	Test method APHA	Results	Acceptable limit IS 10500
<b>Physical Examination</b>					
1	Colour	Hazen	2120 B	< 1	5
2	Taste and odor		2160 A	Agreeable	Agreeable
3	Electrical conductivity	µS/cm	2510 B	673	50-800
4	Turbidity	NTU	2130 B	1	5
5	Total Dissolved solids	mg/L	2540 C	318	500
<b>Chemical Examination</b>					
6	pH	-	4500 H + B	7.21	6.5 - 8.5
7	Total Alkalinity	mg/L	2320 B	96	200
8	Total Hardness as CaCO <sub>3</sub>	mg/L	2340 C	305	200
9	Calcium Hardness as CaCO <sub>3</sub>	mg/L	3500 Ca B	140	
10	Magnesium Hardness as CaCO <sub>3</sub>	mg/L	3500 Mg B	165	
11	Calcium	mg/L	3500 Ca B	56.11	75
12	Magnesium	mg/L	3500 Mg B	40.09	30
13	Chloride	mg/L	4500 Cl <sup>-</sup> B	9.14	250
14	Sulphate	mg/L	4500 SO <sub>4</sub> E	215.09	200
15	Ammonia	mg/L	4500 NH <sub>3</sub> F	BDL	0.5
16	Iron	mg/L	3500 Fe B	0.14	0.3
<b>Bacteriology</b>					
17	Total Coliform	cfu/100ml	9222 B	NIL	Nil / 100ml
18	Faecal Coliform	cfu/100ml	9221 E	NIL	Nil / 100ml

The report is of the sample tested only and shall not be reproduced except in full.

Remarks: Coliforms absent. Total hardness and Magnesium is above the acceptable limit.  
Sulphate is present and above the acceptable limit.  
BDL: Below Detection Level



*[Signature]*

Authorized signatory

AMPLICON BIOLABS  
Room No. 17, Park Centre, KINFRA, Kakkanchery,  
Calicut University P.O, Malappuram 673 635, Kerala  
☎ 0494 240 77 77  
✉ ampliconbiolabs@gmail.com 🌐 www.ampliconbiolabs.com  
Approval No. PCB/CL/RL/4/2009



KERALA STATE POLLUTION CONTROL BOARD APPROVED LABORATORY

Analysis Report

AR No: AR /ABL/1215/ 2022

Date: 21/03/2022

Name: LAND MARK	Date & Time of sample collection: 18/03/2022
Mob:	Sample collected by : Client
Email:	Sample delivered by : Client
Address: Knowledge city, Calicut	Date & Time of delivery : 18/03/2022, 02.50 PM
Source of Sample: BORE WELL -1	Sample received by : Lab Analyst
Sample container: Polythene bottle	Sample condition : Fit for analysis
Type of Test	Period of Analysis : 18/03/2022- 21/03/2022
Chemical <input checked="" type="checkbox"/>	Microbiological <input checked="" type="checkbox"/>

Sl No	Parameter	Unit	Test method APHA	Results	Acceptable limit IS 10500
<b>Physical Examination</b>					
1	Colour	Hazen	2120 B	< 1	5
2	Taste and odor		2160 A	Agreeable	Agreeable
3	Electrical conductivity	µS/cm	2510 B	169	50-800
4	Turbidity	NTU	2130 B	1	5
5	Total Dissolved solids	mg/L	2540 C	79	500
<b>Chemical Examination</b>					
6	pH	-	4500 H <sup>+</sup> B	5.72	6.5 – 8.5
7	Total Alkalinity	mg/L	2320 B	14	200
8	Total Hardness as CaCO <sub>3</sub>	mg/L	2340 C	83	200
9	Calcium Hardness as CaCO <sub>3</sub>	mg/L	3500 Ca B	25	
10	Magnesium Hardness as CaCO <sub>3</sub>	mg/L	3500 Mg B	58	
11	Calcium	mg/L	3500 Ca B	10.02	75
12	Magnesium	mg/L	3500 Mg B	14.09	30
13	Chloride	mg/L	4500 Cl <sup>-</sup> B	27.42	250
14	Sulphate	mg/L	4500 SO <sub>4</sub> E	100.34	200
15	Ammonia	mg/L	4500 NH <sub>3</sub> F	BDL	0.5
16	Iron	mg/L	3500 Fe B	0.043	0.3
<b>Bacteriology</b>					
17	Total Coliform	cfu/100ml	9222 B	NIL	Nil / 100ml
18	Faecal Coliform	cfu/100ml	9221 E	NIL	Nil / 100ml

The report is of the sample tested only and shall not be reproduced except in full.

Remarks: pH below the acceptable limit.  
Coliforms absent.  
BDL: Below Detection Level



*[Signature]*

Authorized signatory

AMPLICON BIOLABS

Room No. 17, Park Centre, KINFRA, Kakkanchery, Calicut University P.O, Malappuram 673 635, Kerala

☎ 0494 240 77 77

✉ ampliconbiolabs@gmail.com 🌐 www.ampliconbiolabs.com

Approval No. PCB/CL/RL/4/2009











Form 59  
(See rules 115 (2))

**Pollution Under Control Certificate**  
Authorised By  
GOVERNMENT OF KERALA

Date : 07/11/2022  
Time : 12:10:33 PM  
Validity upto : 06/11/2023

Certificate SL No : KL01100070021634  
Registration No. : KL11BQ2937  
Date of Registration : 23/Jul/2019  
Month & Year of Manufacturing : January 2018  
Valid Mobile Number : \*\*\*\*\*5268  
Emission Norms : BHARAT STAGE IV  
Fuel : DIESEL  
PUC Code : KL0110007  
GSTIN :  
Fees : Rs. 180.00  
(GST to be paid extra as applicable)  
ML observation : No

Vehicle Photo with Registration plate  
60 mm x 30 mm



Sr. No.	Pollutant (as applicable)	Units (as applicable)	Emission limits	Measured Value (upto 2 decimal places)
1	2	3	4	5
Idling Emissions	Carbon Monoxide (CO)	percentage (%)		
	Hydrocarbon, (THC/HC)	ppm		
High idling emissions	CO	percentage (%)		
	RPM	RPM	2500 ± 200	
Smoke Density	Lambda	-	1 ± 0.03	
	Light absorption coefficient	1/metre	1.62	0.28

This PUC certificate is system generated through the national register of motor vehicles and does not require any signature.

Note : 1. Vehicle owners to link their mobile numbers to registered vehicle by logging to <https://vahan.parivahan.gov.in>

Authorised Signature with stamp of PUC operator  
60mm x 20 mm

1 of 1





**TEST REPORT**

Test Report No: 20211220/R018	Date: 24-12-2021	Page 1 of 2
-------------------------------	------------------	-------------

CUSTOMER DETAILS	
Customer Name & Address	M/s Calicut Landmark Builders & Developers India Pvt. Ltd. Kodenchery Village, kodenchery, Kozhikode District
Customer Reference	Test Request dt: 20-12-2021

SAMPLE DETAILS			
Product Category	Water	Sample Code	20211220/B018
Sample Name	Open Well	Sample Received on	21-12-2021
Sample Conditions at Receipt	Fit for Analysis	Temperature @ Receipt	27 °C
Sample Quantity& Packing	1L & 100ml Plastic Bottle	Test Commenced on	21-12-2021
Sampled by	Not Drawn by Laboratory	Test Completed on	23-12-2021

SAMPLING SITE DETAILS			
Survey No.	15/1,33/1		
Village	Kodenchery	Taluk	Thamarassery
District	Kozhikode	State	Kerala

TEST RESULTS- CHEMICAL PARAMETERS					
Sl.No.	PARAMETERS	TEST METHOD	UNIT	RESULT	Requirement as per Acceptable Limit of IS 10500 :2012
1	Colour	IS 3025 (Part 4):1983 RA 2017	Hazen	1	Max 5
2	Odour	IS 3025 (Part 5):2018	---	Agreeable	Agreeable
3	Turbidity	IS 3025 (Part 10):1984 RA 2017	NTU	0.1	Max 1
4	pH	IS 3025 (Part 11):1983 RA 2017	---	6.95	6.50 - 8.50
5	Conductivity	IS 3025 (Part 14):1984 RA 2019	µS/cm	102	---
6	Total Dissolved Solids	IS 3025 (Part 16):1984 RA 2017	mg/L	66.0	Max 500
7	Total Hardness as CaCO <sub>3</sub>	IS 3025 (Part 21):2009 RA 2019	mg/L	28.0	Max 200
8	Calcium as Ca	IS 3025 (Part 40):1991 RA 2019	mg/L	8.00	Max 75
9	Magnesium as Mg	IS 3025 (Part 46):1994 RA 2019	mg/L	1.95	Max 30
10	Chloride as Cl	IS 3025 (Part 32):1988 RA 2019	mg/L	16.9	Max 250
11	Total Alkalinity as CaCO <sub>3</sub>	IS 3025 (Part 23):1986 RA 2019	mg/L	14.0	Max 200
12	Iron as Fe	IS 3025 (Part 53):2003 RA 2019	mg/L	0.10	Max 1
13	Sulphate as SO <sub>4</sub>	IS 3025 (Part 24):1986 RA 2019	mg/L	1.10	Max 200

  
**Shency Joy**  
 Dy.TM-Chemical  
 Checked by



  
**Salsini T.S.**  
 Microbiologist  
 Authorized Signatory

  
**Laila P.N.**  
 Laboratory Head  
 Authorized Signatory

The results are valid only for the samples submitted for analysis and this report is valid only as reproduced except in full without the written approval of the laboratory.

**Standard Environmental & Analytical Laboratories**  
 Approval & Recognition: "A" Grade Laboratory approved by Kerala State Pollution Control Board.  
 K.J. Tower, Kothamangalam, Trivandrum-685 501, Tel: 0474-2546650, 93 87 27 24 02, 90 74 14 14 43  
 Web: www.sealab.in, E-mail: sealab@gmail.com



**TEST REPORT**

Test Report No: 20211220/R016	Date: 24-12-2021	Page 1 of 1
-------------------------------	------------------	-------------

**CUSTOMER DETAILS**

Customer Name & Address	M/s Calicut Landmark Builders & Developers India Pvt. Ltd. Kodenchery Village, Kodenchery, Kozhikode District
Customer Reference	Test Request dt: 20-12-2021

**SAMPLE DETAILS**

Product Category	Atmospheric Pollution	Sample Code	20211220/S016
Sample Name	Ambient Air	Sample Received on	20-12-2021
Sample Conditions at Receipt	Fit for Analysis	Test Commenced on	21-12-2021
Sampled by	Lab Authorized Sampler	Test Completed on	23-12-2021

**DETAILS OF SAMPLING**

Sampling Location	East Side Boundary	Date of Sampling	20-12-2021
Sampling Procedure	SEAAL/EHL/GEN/SOP/02	Humidity	69%

**SAMPLING SITE DETAILS**

Survey No.	15/1,33/1		
Village	Kodenchery	Taluk	thamarassery
District	Kozhikode	State	Kerala

**TEST RESULTS- CHEMICAL PARAMETERS**

Sl. No.	PARAMETERS	TEST METHOD	UNIT	RESULT	NAAO Standards
1	Particulate Matter, PM <sub>10</sub>	IS 5182 (Part 23):2006	µg/m <sup>3</sup>	58.0	Max 100
2	Particulate Matter, PM <sub>2.5</sub>	EPA 40 CFR (Part 50) Appendix - L	µg/m <sup>3</sup>	24.2	Max 60
3	Sulphur Dioxide as SO <sub>2</sub>	IS 5182 (Part 2): 2001 RA 2017	µg/m <sup>3</sup>	< 2.00	Max 80
4	Oxides of Nitrogen as NO <sub>2</sub>	IS 5182 (Part 6): 2006 RA 2017	µg/m <sup>3</sup>	< 2.00	Max 80

Remarks:

\*\*\*End of Report\*\*\*

  
Riya Joseph  
Technical Manager  
Checked by:



  
Lalju P.N.  
Laboratory Head  
Authorized Signatory

This report is related only to the sample submitted for analysis and this test report shall not be reproduced (total or full) without the written approval of the laboratory.

**Standard's Environmental & Analytical Laboratories**  
Approval & Recognition: "A" Grade Laboratory approved by Kerala State Pollution Control Board.  
K.L. Tower, Panchalam, Udyogmandal P.O., Emakulam-683 507, Tel: 0484-2516660, 93-87 27 24 02, 90 74 34 14 43  
Web: www.sealab.com, E-mail: sealab@gmail.com



**TEST REPORT**

Test Report No: 20211220/R017	Date: 24-12-2021	Page 1 of 1
-------------------------------	------------------	-------------

**CUSTOMER DETAILS**

<b>Customer Name &amp; Address</b>	M/s Calicut Landmark Builders & Developers India Pvt. Ltd. Kodenchery Village, Kodenchery, Kozhikode District
<b>Customer Reference</b>	Test Request dt: 20-12-2021

**DETAILS OF MONITORING**

<b>Product Category</b>	Atmospheric Pollution	<b>Sample Code</b>	20211220/S017
<b>Sample Name</b>	Ambient Noise	<b>Monitoring Commenced on</b>	20-12-2021 / 06:00
<b>Monitoring Location</b>	East Side boundary	<b>Monitoring Completed on</b>	21-12-2021 / 06:00
<b>Test Method</b>	IS 9989:1981 RA:2008	<b>Monitored by</b>	Lab Authorized Sampler

**MONITORING SITE DETAILS**

<b>Survey No.</b>	15/1,33/1		
<b>Village</b>	Kodenchery	<b>Tahuk</b>	thamarassery
<b>District</b>	Kozhikode	<b>State</b>	Kerala

**MONITORING RESULTS - Leq**

TIME	RESULTS dB(A)	TIME	RESULTS dB(A)	TIME	RESULTS dB(A)
06:00	42.6	14:00	57.1	22:00	41.3
07:00	48.7	15:00	57.5	23:00	35.3
08:00	50.5	16:00	58.8	24:00	37.9
09:00	54.4	17:00	59.3	01:00	35.6
10:00	57.1	18:00	53.1	02:00	38.2
11:00	60.6	19:00	49.2	03:00	35.9
12:00	57.5	20:00	44.8	04:00	37.9
13:00	56.6	21:00	44.3	05:00	39.7

**TEST RESULTS**

Sl. No.	PARAMETERS	UNIT	RESULT
1	Ambient Sound Level (Leq) Day Time (06:00 to 23:00)	dB(A)	55.6
2	Ambient Sound Level (Leq) Night Time (23:00 to 06:00)	dB(A)	38.1

Remarks:

\*\*\*End of Report\*\*\*

  
**Riya Joseph**  
 Technical Manager  
 Checked by:



  
**Laju P.N.**  
 Laboratory Head  
 Authorized Signatory

The results are valid only if the samples submitted for analysis and this test report of all our test reproduced exactly as full, with the written approval of the laboratory.

**Standard Environmental & Analytical Laboratories**

Approval & Recognition: "A" Grade Laboratory approved by Kerala State Pollution Control Board.

K.I. Tower, Panchalath, Udyogamandal P.O., Emakulam-683 501, Tel: 0184-2546660, 93 87 27 24 02, 90 74 34 14 43  
 Web: www.standardlab.com, E-mail: standardlab@gmail.com

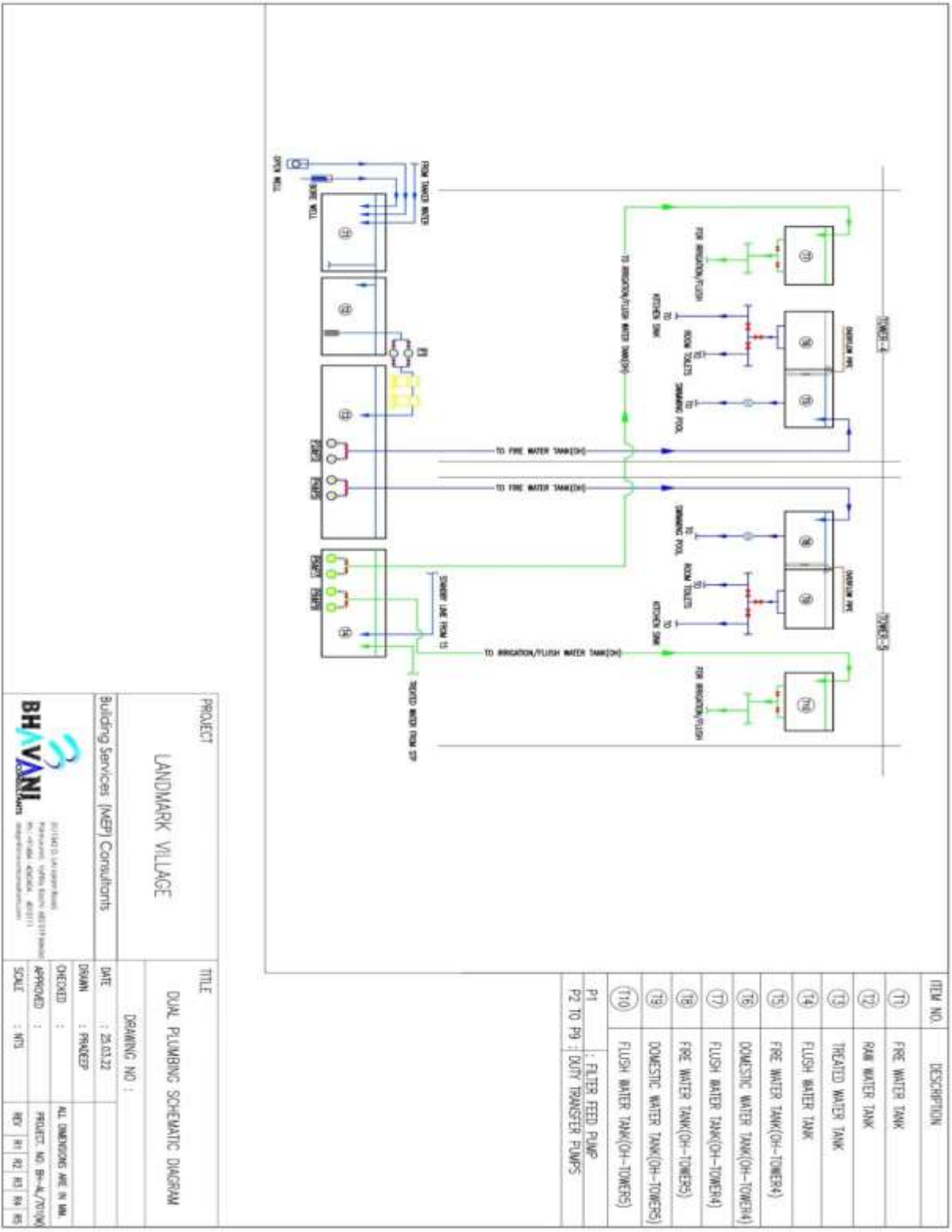

PROJECT	LANDMARK VILLAGE	TITLE	DUAL PLUMBING SCHEMATIC DIAGRAM
Building Services (MEP) Consultants		DRAWING NO :	
		DATE :	25.03.22
		DRAWN :	PRADHEEP
		CHECKED :	ALL DIMENSIONS ARE IN MM.
		APPROVED :	PROJECT NO BH-4/7010K
		SCALE :	HTS
			REV : 01 02 03 04 05





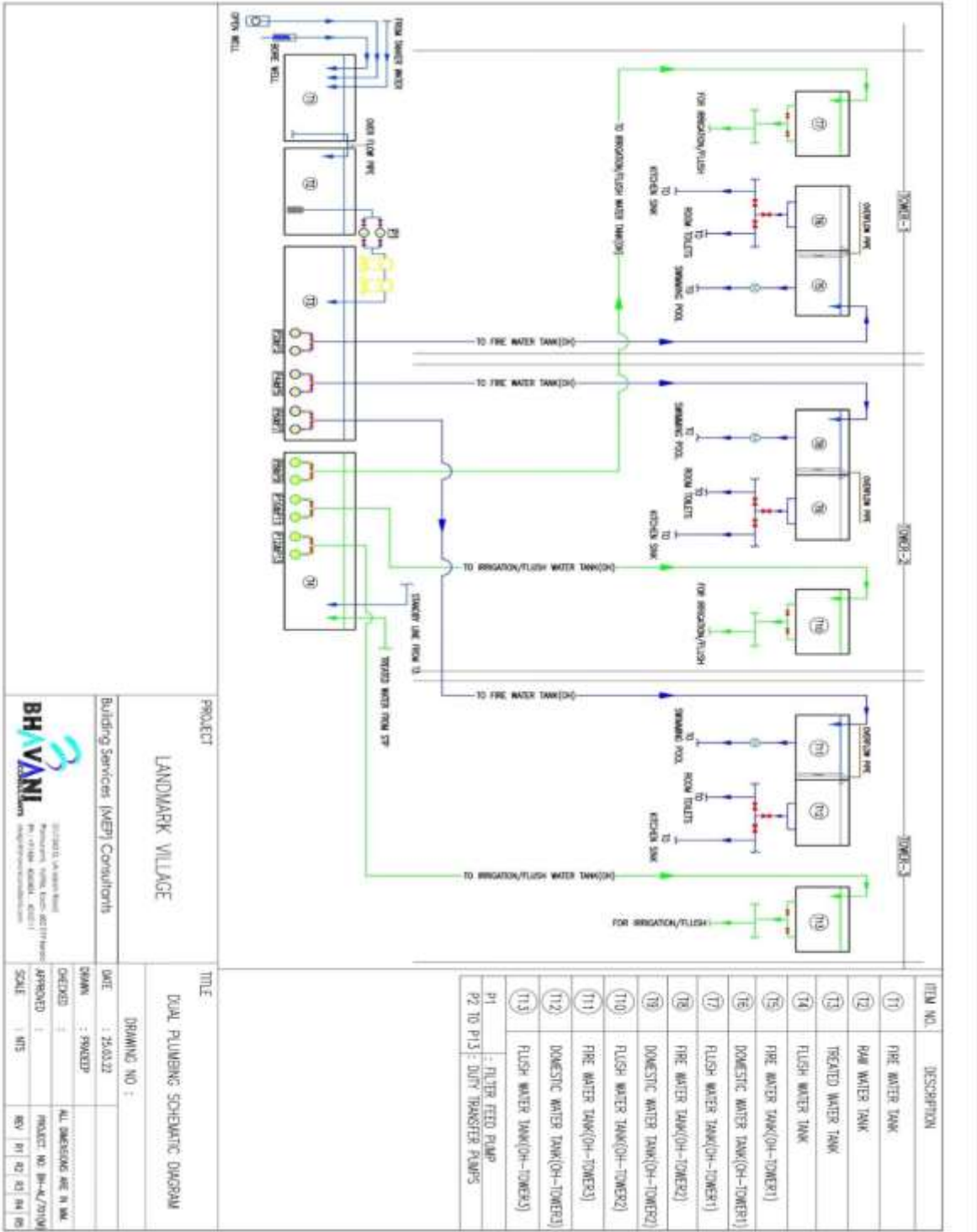



Julu Centre, West Hill,  
Kozhikode, Kerala, 673005  
Ph: +91 9896810432,  
8498 2362432, 4011432  
E-mail: jitheshpvtltd@gmail.com  
Website: www.jitheshengineers.com  
CIN:U74200KL2004PTC030373

DATE: 25-03-2023

**STABILITY CERTIFICATE**

This is to certify that the structural design of the proposed (Basement + Ground + 07 FLOOR) started building LANDMARK VILLAGE TS, Kodaneri Village, Thannarayana Taluk, Kozhikode District, PIN code 673 580 in Rs.survey no. 15/1 & 33/1 is prepared by me and the design is satisfied the requirements of standards/guidelines of IS 1875 1987 and seismic load as per IS 1893-2009. Also, I certified that the site has been inspected by me and the design is found structurally stable for constructing the proposed building at the land mentioned above.



E. K. JITHESH, M.Tech (Strl Engg.), MIE, CEng  
Structural Engineer & Chartered Engineer  
Reg.No: M-148102-9

 **Jithesh Engineers Pvt. Ltd.**  
Structural Engineers  
Julu Centre, West Hill, Kozhikode, Kerala - 673005  
Ph: +91 9896810432



DEPARTMENT OF FIRE & RESCUE SERVICES  
GOVERNMENT OF KERALA

No. F2-13199/16

Date: 17.10.2016

**FIRE SAFETY CLEARANCE FOR SITE**

1. Name & Address of the Applicant : **Moideen Koya Edakkott  
M.D.Cliffvale Projects Pvt Ltd & Corpwale Projects  
Pvt Ltd, First Floor, Markaz Commercial Complex,  
Indhira Gandhi Road, Kozhikode-673001.**
2. Name of the Company : -
3. Occupancy type of Building : **Tower 1 to 4-Residential Building  
Tower 5-Residential Cum Mercantile Building**
4. Height of the Building : **Tower 1-58.65 mtrs  
Tower 2-58.05 mtrs  
Tower 3-58.65 mtrs  
Tower 4-58.05 mtrs  
Tower 5-59.85 mtrs (Mercantile – 13.80 mtrs  
Residential – 46.05 mtrs)**
5. Number of Floors of the Building : **Tower 1 - 20 F (G+19 F)  
Tower 2 - 21 F (B+G+19 F)  
Tower 3 & 4 - 20 F (G+19 F)  
Tower 5 - 19 F (B+G+17 F)  
Residential – 16 F (2<sup>nd</sup> F to 17<sup>th</sup> F )  
Mercantile – 3 F (B+G+1 F)**
6. Total Plinth Area (in sqm) : **Tower 1 – 19691.88 m<sup>2</sup>  
Tower 2 – 23341.11 m<sup>2</sup>  
Tower 3 – 18355.13 m<sup>2</sup>  
Tower 4 – 15333.02 m<sup>2</sup>  
Tower 5 – 66153.03 m<sup>2</sup>  
Residential – 47481.56 m<sup>2</sup>  
Mercantile – 18671.47 m<sup>2</sup>**
7. Re-Survey No : **15/1, 33/1**
8. Village : **Kodenchery**
9. Grama Panchayath : **Kodenchery**
10. District : **Kozhikode**



**നോട്ടീസ്**

പൊതുജന ശ്രദ്ധയ്ക്കായി, കേരള സംസ്ഥാനം, കോഴിക്കോട് ജില്ല താമരശ്ശേരി താലൂക്ക് കോടൻചേരി പഞ്ചായത്ത് കോടൻചേരി വില്ലേജിൽ സർവ്വേ No: 15/1 & 33/1 ഉൾപ്പെട്ട സ്ഥലത്ത് ടൗൺഷിപ്പ് കെട്ടിട നിർമ്മാണ പദ്ധതിക്കായി കാലിക്കറ്റ് ലാൻഡ് മാർക്ക് ബിൽഡേഴ്സ് & ഡവലപ്പേഴ്സ് (ഇന്ത്യ) പ്രൈ. ലി. എന്ന സ്ഥാപനം സമർപ്പിച്ച അപേക്ഷയിൽ വേണ്ട പരിസ്ഥിതി അനുമതി, പരിസ്ഥിതി വന കാലാവസ്ഥ വ്യതിയാന മന്ത്രാലയത്തിൽ നിന്നും ഓർഡർ നമ്പർ 909/SEIAA/EC4/3588/2015 തീയതി 28.12.2019 ഓർഡർ പ്രകാരം ലഭിച്ചിരിക്കുന്നു. ഈ ഓർഡറിന്റെ പകർപ്പ് സംസ്ഥാന മലിനീകരണ നിയന്ത്രണ ബോർഡിൽ ലഭ്യമാണ്. കൂടാതെ പരിസ്ഥിതി വന കാലാവസ്ഥ വ്യതിയാന മന്ത്രാലയത്തിന്റെ <http://www.seiaakerala.org> എന്ന വെബ്സൈറ്റിൽ കൂടിയും പകർപ്പ് കാണാവുന്നതാണ്.

ഒപ്പ്  
ഡയറക്ടർ,  
കാലിക്കറ്റ് ലാൻഡ് മാർക്ക് ബിൽഡേഴ്സ് & ഡവലപ്പേഴ്സ് (ഇന്ത്യ) പ്രൈ. ലി.